

AB COCKS ABM

ABM 12 X-KAF, PN160, G1/4"



Product details

- » Straight through cock
- » PN160
- » Cylindrical plug
- » Stainless steel X
- » Elastic packing sleeve KAF
- » With hand lever

Connections Threaded G1/4"

Certificates VDI 2440

Dimensions Body length 70 mm

General features

- » 90°-rotation ensures immediate opening and closing procedure
- » Hand operation enables throttling, therefore usage in blow-down lines possible
- » Simple maintenance: The packing sleeve can be replaced within minutes with the cock staying in the line
- » No jamming caused by corrosion

Temperature X-KAF -200°C to +400°C, PN160

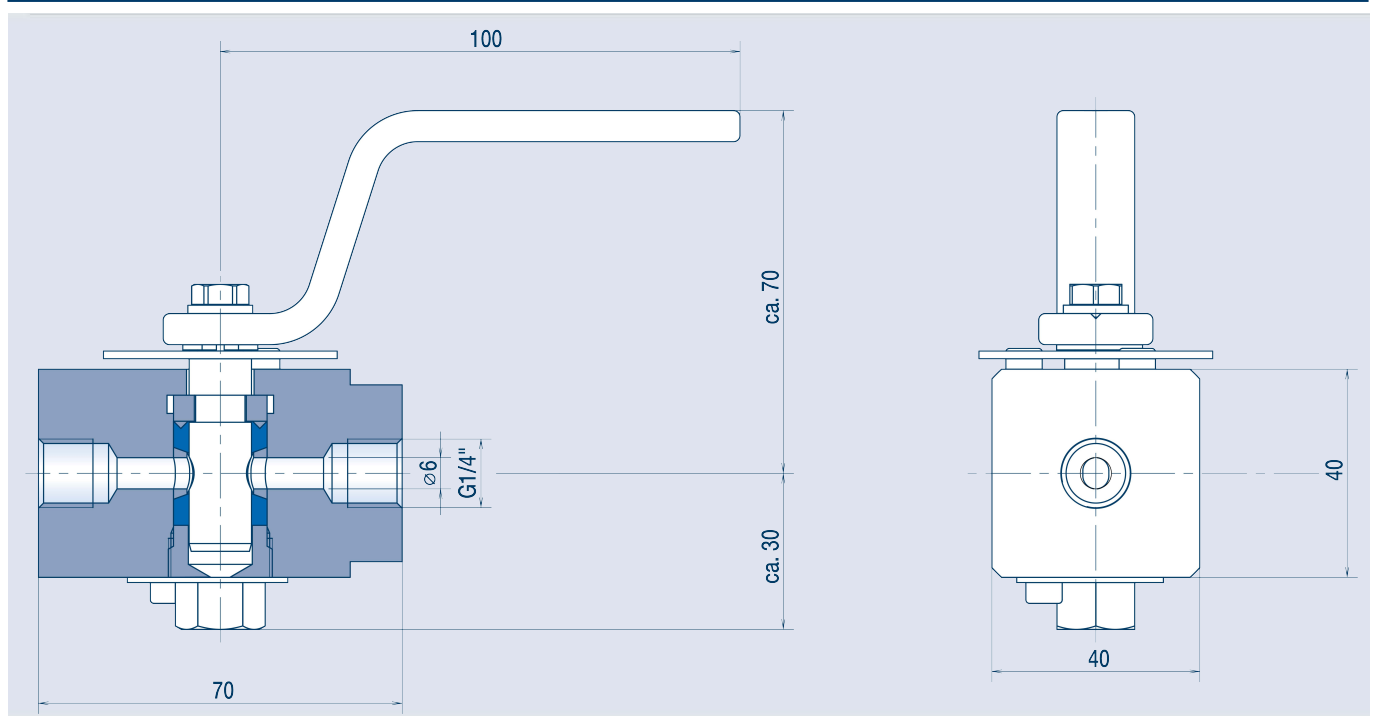

Application range

District Heating | Processing industry | Automation | Geothermal energy | Shipbuilding industry | Diesel engines | Oil & Gas | Compressed-air supply | Instrumentation & Control | Electric supply | Energy generating companies

The packing sleeve

Under pressure the lamellas of the elastic packing sleeve are pressed against the body wall and thereby an excellent seal is achieved. The KAF is suitable for high temperatures up to 400°C.



AB COCKS ABM

Pressure and temperature ranges / Parts list

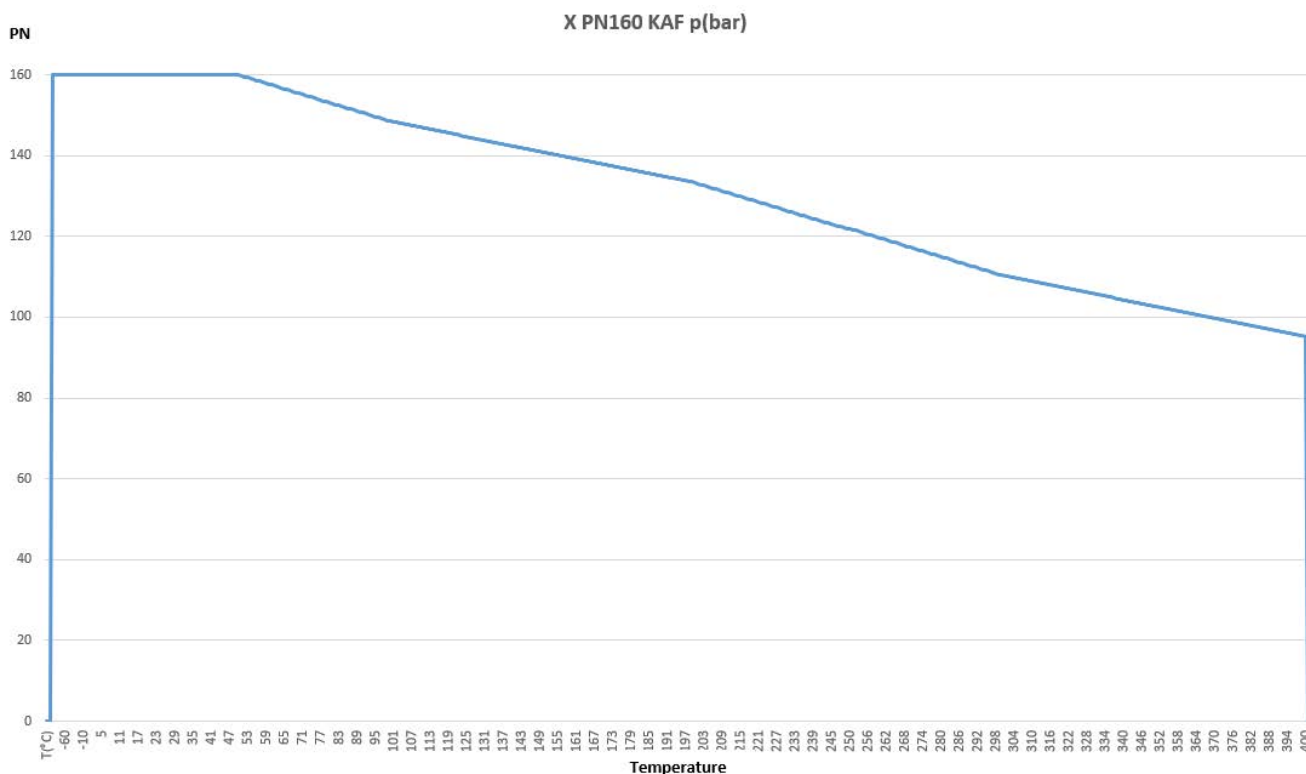

Parts list

Pos.	number	name
1	1	Body
2	1	Packing sleeve
3	1	Cock plug
4	2	Split ring
5	1	Tightening nut
6	1	Locking disc
7	3	Fillister head screw
8	1	Stop
9	1	Secure ring
10	1	Hand lever
11	1	Disc
12	1	Hexagon head screw
13	1	Gasket
14	1	Screw plug
15	2	Tightening screw

